

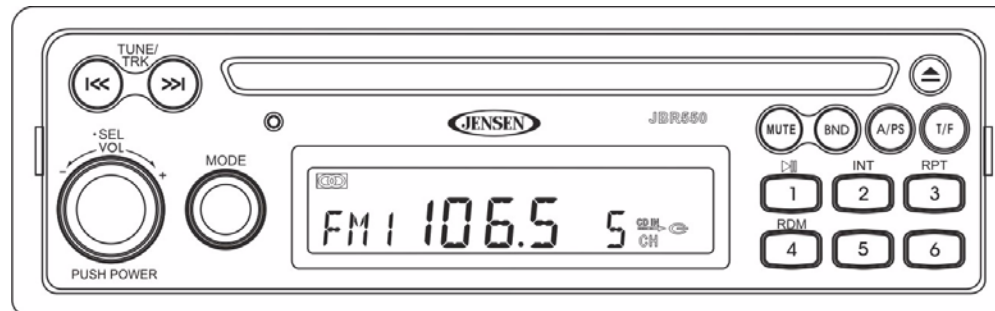

JBR550

AM/FM/CD AUDIO SYSTEM with PA

Installation and Operation Manual





CONTENTS

System Features	1
Safety Information	2
Installation	3
Basic Operation	6
Tuner Operation	8
CD Player Operation	9
Care and Maintenance	10
Troubleshooting	10
Specifications	11

SYSTEM FEATURES

Features of the Jensen JBR550 mobile audio system include:

- AM/FM Tuner with 30 Presets (12 AM, 18 FM)
- Single In-Dash CD Player
- Public Announcement (PA) Feature with Optional Microphone (sold separately)
- Mute
- Electronic Bass, Treble, Balance and Fader Controls
- Clock

Content List

- Jensen Main Chassis
- Hardware Kit
- Wiring Harnesses (4-pin and 9-pin)
- Installation Manual

Hardware Kit

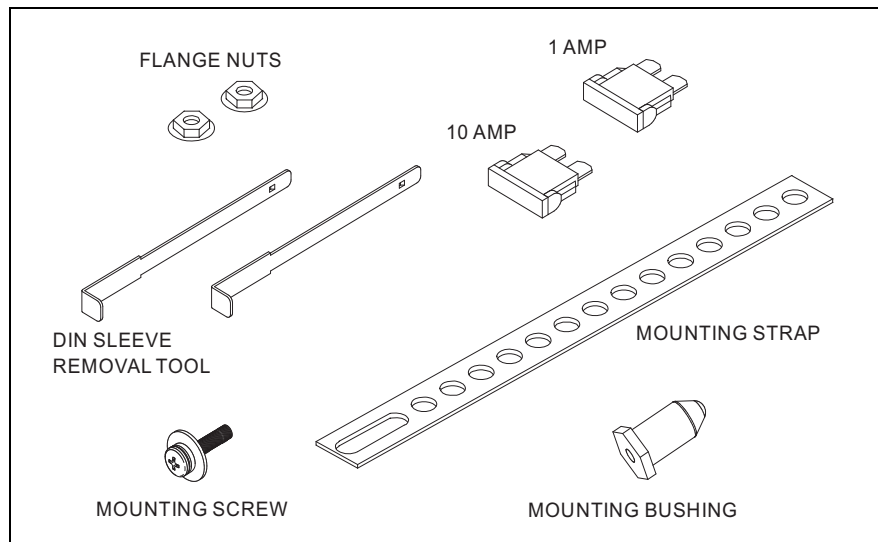

SAFETY INFORMATION

When Driving

Keep the volume level low enough to be aware of the road and traffic conditions.

When Washing your Vehicle

Do not expose the product to water or excessive moisture. Moisture can cause electrical shorts, fire or other damage.

When Parked

Parking in direct sunlight can produce very high temperatures inside your vehicle. Give the interior a chance to cool down before starting playback.

Use the Proper Power Supply

This product is designed to operate with a 12 volt DC negative ground battery system.

Protect the Disc Mechanism

Avoid inserting any foreign objects into the disc slot. Misuse may cause malfunction or permanent damage due to the precise mechanism of this unit.

CAUTION:

THIS MOBILE CD PLAYER IS A CLASS I LASER PRODUCT. THIS UNIT USES A VISIBLE/ INVISIBLE LASER BEAM WHICH COULD CAUSE HAZARDOUS RADIATION IF EXPOSED DIRECTLY. BE SURE TO OPERATE THE MOBILE CD PLAYER AS INSTRUCTED.

USE OF CONTROLS OR ADJUSTMENTS, OR PERFORMANCE OR PROCEDURES OTHER THAN THOSE SPECIFIED HEREIN MAY RESULT IN HAZARDOUS RADIATION EXPOSURE.

DO NOT OPEN COVERS AND DO NOT REPAIR BY YOURSELF. PLEASE REFER SERVICING TO A QUALIFIED TECHNICIAN.

WARNING:

- TO REDUCE THE RISK OF FIRE OR ELECTRIC SHOCK, DO NOT EXPOSE THIS EQUIPMENT TO RAIN OR MOISTURE.
- TO REDUCE THE RISK OF FIRE OR ELECTRIC SHOCK AND ANNOYING INTERFERENCE, USE ONLY THE RECOMMENDED ACCESSORIES.

DISC NOTES

Depending on the recording status, conditions of the disc, and the equipment used for recording, some CD-Rs/CD-RWs may not play on this unit. For more reliable playback, please adhere to the following recommendations:

- Use CD-RWs with speed 1x to 4x and write with speed 1x to 2x.
- Use CD-Rs with speed 1x to 8x and write with speed 1x to 2x.
- Do not play a CD-RW which has been written more than 5 times.

NOTE: CD-R and CD-RW discs will not play unless the recording session is closed and the CD is finalized.

Disc Maintenance

- A dirty or defective disc may cause sound dropouts while playing. Before playing, wipe the disc using a clean cloth, working from the center hole towards the outside edge. Never use benzene, thinners, cleaning fluids, anti-static liquids or any other solvent.

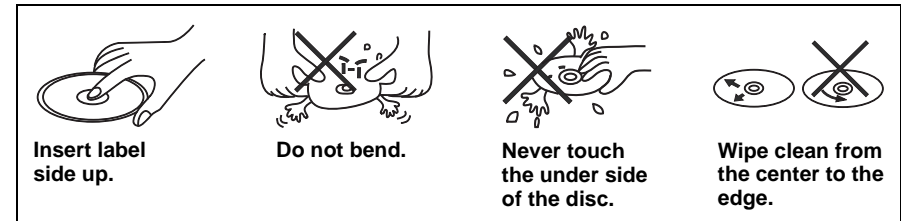

- Be sure to use only round CDs for this unit and do not use any special shape CDs. Use of special shape CDs may cause the unit to malfunction.
- Do not stick paper or tape on the disc. Do not use CDs with labels or stickers attached or that have sticky residue from removed stickers.
- Do not expose discs to direct sunlight or heat sources.

NOTE: A disc may become scratched (although not enough to make it unusable) depending on how you handle it and other conditions in the usage environment. These scratches are not an indication of a problem with the player.

INSTALLATION

Before You Begin

1. **Disconnect Battery**
Before you begin, always disconnect the battery negative terminal.
2. **Remove Transport Screws**

Important Notes

- Before final installation, test the wiring connections to make sure the unit is connected properly and the system works.
- Use only the parts included with the unit to ensure proper installation. The use of unauthorized parts can cause malfunctions.
- Consult with your nearest dealer if installation requires the drilling of holes or other modifications to your vehicle.
- Install the unit where it does not interfere with driving and cannot injure passengers if there is a sudden or emergency stop.
- If the installation angle exceeds 30° from horizontal, the unit may not give optimum performance.
- Avoid installing the unit where it will be subject to high temperatures from direct sunlight, hot air, or from a heater, or where it would be subject to excessive dust, dirt or vibration.

DIN Radio Installation

This unit is designed for installation in vehicle cabs with an existing 1-DIN radio opening. In many cases, a special installation kit will be required to mount the radio to the dashboard. These kits are available at electronics supply stores and car stereo specialty shops. Always check the kit application before purchasing to make sure the kit works with your vehicle.

Universal Installation (Using Mounting Sleeve)

1. Slide the mounting sleeve off of the chassis. If it is locked into position, use the removal keys (supplied) to disengage it.
2. Check the dashboard opening size by sliding the mounting sleeve into it. If the opening is not large enough, carefully cut or file as necessary until the sleeve slides easily into the opening. Do not force the sleeve into the opening or cause it to bend or bow. Check that there will be sufficient space behind the dashboard for the radio chassis. Connect wires prior to actually installing the sleeve. Pigtail wiring should take place after hole size is confirmed. Mount sleeve after wiring.
3. Follow the wiring diagram carefully and make certain all connections of the wiring harness are properly secured and insulated to insure proper operation of this unit. After completing the wiring connections, turn the unit on to confirm operation (ignition switch must be "on"). If unit does not operate, recheck all wiring until the problem is corrected. Once proper operation is achieved, turn off ignition switch and proceed with final mounting of the chassis.
4. Locate the series of bend tabs along the top, bottom, and sides of the mounting sleeve. With the sleeve fully inserted into the dash opening, bend tabs outward so that the sleeve is firmly secured to the dashboard.
5. Carefully slide the radio into the mounting sleeve making sure it is right side up until it is fully seated and the spring clips lock it into place.
6. Attach one end of the perforated mounting strap (supplied) to the screw stud on the rear of the chassis using the flange nut provided. Fasten the other end of the perforated strap

to a secure part of the dashboard, either above or below the radio using the screw and flange nut provided. Bend the strap to position it as necessary.

CAUTION: The rear of the radio must be supported with either the perforated strap or the rubber mounting bushing to prevent damage to the dashboard from the weight of the radio or improper operation due to vibration.

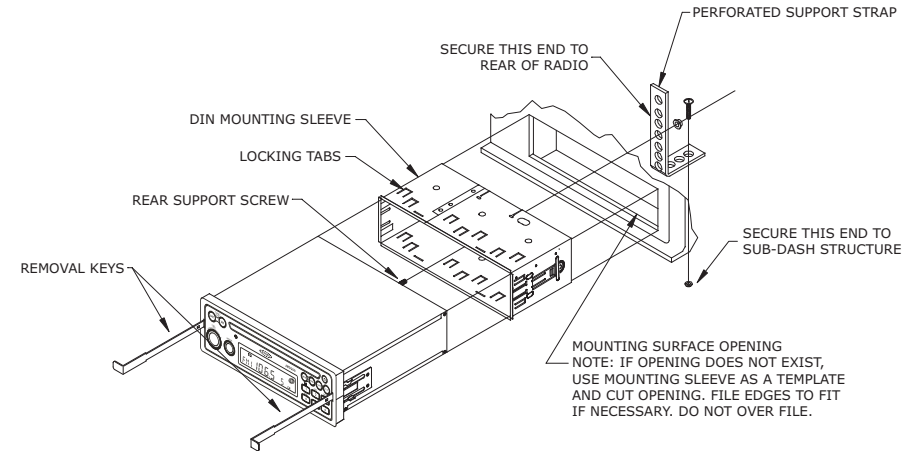

Kit Installation

1. If your radio requires the use of an installation kit to mount this radio, follow the instructions included in the kit to attach the radio to the mounting plate supplied with the kit.
2. Wire and test the radio as described.
3. Install the radio/mounting plate assembly to the sub-dash according to the instructions of the installation kit.
4. Attach the support strap to the radio and dashboard as described above.
5. Replace the dashboard trim panel.

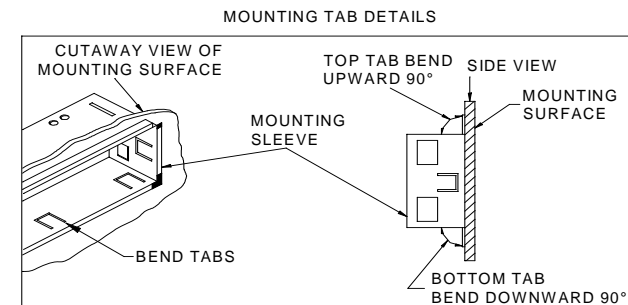

Wiring Diagram

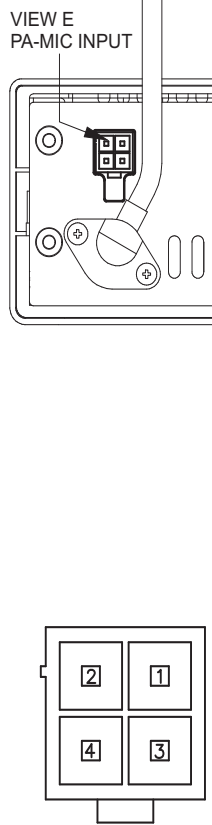
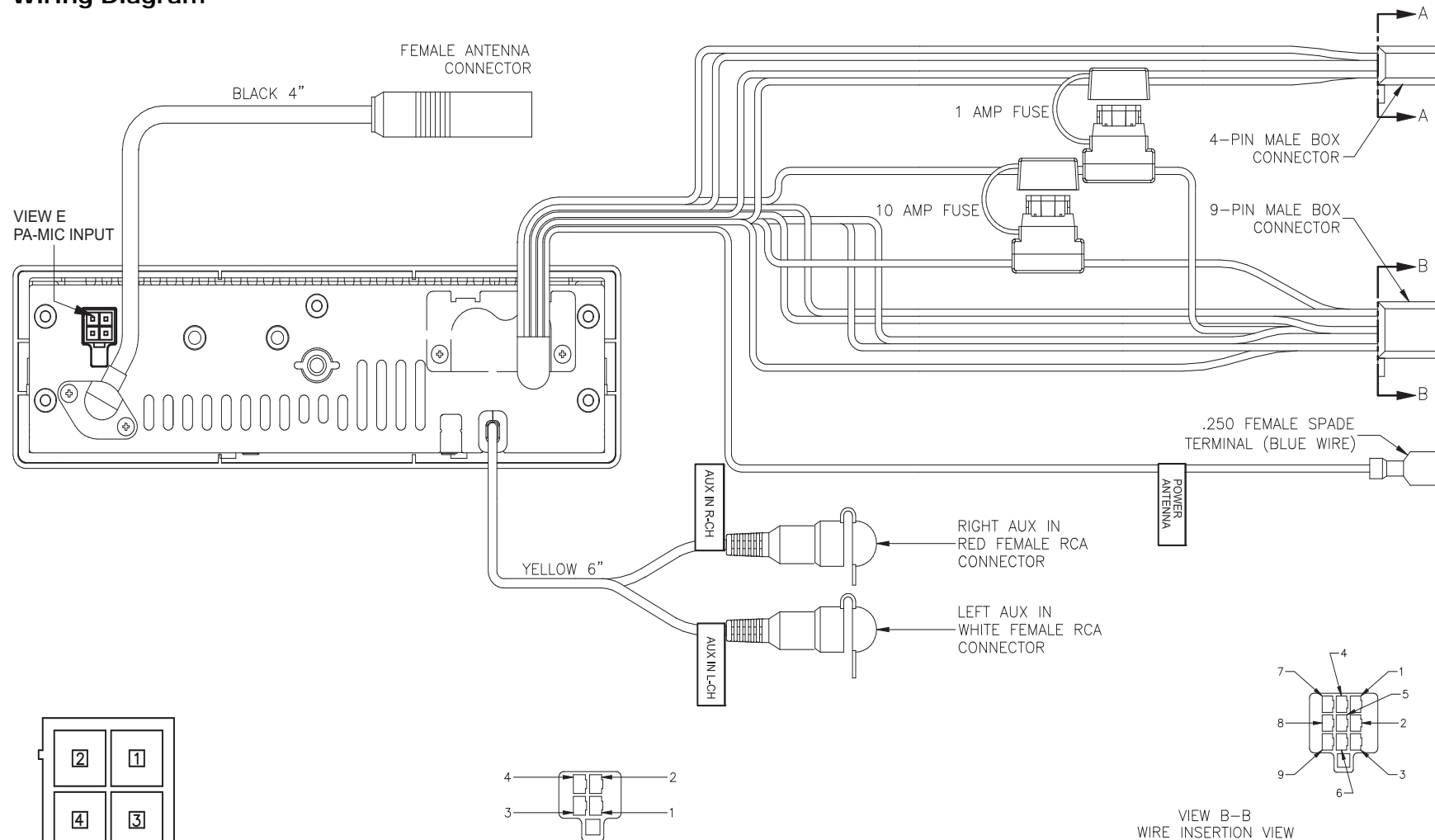

PIN NO.	4PIN SOCKET
1	MIC(+)
2	MIC(-)
3	MIC SWITCH(+)
4	MIC SWITCH(-)

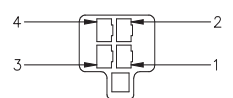

PIN NO.	WIRE COLOR	GAUGE	DESCRIPTION
1	GREEN	20	LEFT REAR SPEAKER (+)
2	VIOLET	20	RIGHT REAR SPEAKER (+)
3	GREEN/BLACK	20	LEFT REAR SPEAKER (-)
4	VIOLET/BLACK	20	RIGHT REAR SPEAKER (-)

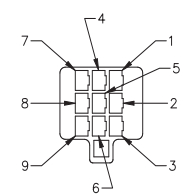

PIN NO.	WIRE COLOR	GAUGE	DESCRIPTION
1	EMPTY	-	NO CONNECTION
2	WHITE/BLACK	20	LEFT FRONT SPEAKER (-)
3	EMPTY	-	NO CONNECTION
4	WHITE	20	LEFT FRONT SPEAKER (+)
5	GRAY/BLACK	20	RIGHT FRONT SPEAKER (-)
6	GRAY	20	RIGHT FRONT SPEAKER (+)
7	RED	20	+12V SWITCHED (WITH/1A FUSE)
8	YELLOW	18	+12V BATTERY (WITH/10A FUSE)
9	BLACK	18	GROUND

Reconnecting the Battery

When wiring is complete, reconnect the battery negative terminal.

Removing the Unit

To remove the radio after installation, insert the removal keys straight back until they click, and then pull the radio out. If removal keys are inserted at an angle, they will not lock properly to release the unit.

BASIC OPERATION

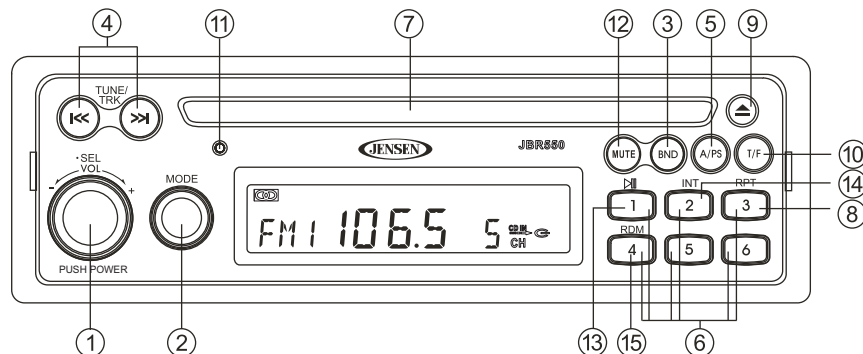

Power On/Off

Press the rotary encoder **POWER** button (1) to turn the unit on. *Press and hold* to turn the unit off. The unit will resume at the last mode selected (Tuner, Aux, etc.).

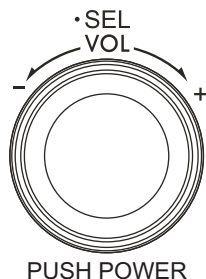

Volume Control

To increase the volume, turn the rotary encoder (1) to the right. To decrease the volume, turn the rotary encoder to the left. While adjusting the volume, the LCD displays a numerical representation of the level. The maximum volume setting is "63".

Mute

Press the **MUTE** button (12) on the control panel to mute the audio output. Press **MUTE** again to restore the audio output to the previous level.

Mode

Press the **MODE** button (2) on the control panel to select a different mode of operation, as indicated on the display panel. Available modes include Tuner (AM/FM), CD, and LINE (optional Auxiliary Input).

NOTE: CD mode will be skipped if no CD is inserted.

Reset

Use a ball point pen or thin metal object to press the **RESET** button (11). The reset button should be activated for the following reasons:

- initial installation of the unit when all wiring is completed
- function buttons do not operate
- error symbol on the display

Audio Menu

With the radio on, press the **SEL** button/rotary encoder (1) on the control panel to access the audio menu. You can navigate through the audio menu items by pressing the **SEL** button repeatedly. Once the desired menu item appears on the display, adjust that option by turning the rotary encoder within 5 seconds. The unit will automatically exit the audio menu after five seconds of inactivity. The following menu items can be adjusted.

BASS Level

Use the rotary encoder to adjust the Bass level range from "-7" to "+7".

TREBLE Level

Use the rotary encoder to adjust the Treble level range from "-7" to "+7".

Balance (BAL)

Use the rotary encoder to adjust the Balance between the left and right speakers from "L15" (full left) to "R15" (full right).

Fader (FAD)

Use the rotary encoder to adjust the Fader between the rear and front speakers from "R15" (full rear) to "F15" (full front).

LOUD

Use the rotary encoder (1) to turn the LOUD feature "on" or "off". "Off" is the default setting.

Auxiliary Input (LINE)

To access an auxiliary device:

1. Connect the portable audio player to the AUX IN input cables on the back of the radio.
2. Press the **MODE** button (2) to select LINE mode. "LINE" will appear on the display.
3. Press **MODE** again to cancel LINE mode and go to the next mode.

PA Operation (microphone sold separately)

- Connect the PA Microphone with a 4-PIN connector to the 4-PIN socket on the rear of the unit.
- The unit will automatically switch to PA mode when the Mic switch is pushed "ON".
- The PA output level can be adjusted using the rotary volume encoder (1).
- With radio power off, the radio will wake up when PA mic is keyed to make an announcement. Please note that it will take a few seconds before the radio "wakes up" and PA is active. Radio will return to the off state when the PA mic is released.

Liquid Crystal Display (LCD)

The current frequency and activated functions are shown on the LCD panel.

NOTE: LCD panels may take longer to respond when subjected to cold temperatures for an extended period of time. In addition, the visibility of the numbers on the LCD may decrease slightly. The LCD display will return to normal when the temperature increases to a normal range.

Time/Frequency Display Selector (T/F)

Displaying the Clock

Press the **T/F** button (10) to display the time of the incorporated quartz clock for 5 seconds.

Setting the Clock

1. To set the clock, first turn the vehicle ignition and radio on.
2. *Press and hold* the **T/F** button (10).
3. Press the **TUNE/TRK** |<< and >>| buttons (4) to adjust the hours. "AM" or "PM" will appear on the display to indicate AM or PM.
4. Press the **T/F** button again to move the cursor to the minutes position, and then use the **TUNE/TRK** |<< and >>| buttons to adjust the minutes.
5. After five seconds, normal operation will resume.

TUNER OPERATION

Select a Band

Press the **BND** button (3) to change between three FM bands and two AM bands.

- During FM operation, when the station is broadcasting in stereo, the stereo icon (Ⓔ) appears on the display.
- During AM operation, no indications are displayed.

Manual Tuning

Press the **TUNE/TRK >>|** or **|<<** buttons (4) to manually step tune to the next or previous frequency.

Auto Seek Tuning

Press and hold the **TUNE/TRK >>|** or **|<<** buttons (4) to automatically seek the next strong station.

Preset Stations

Six numbered preset buttons store and recall stations for each band.

Store a Station

Select a band (if needed), then select a station. Press and hold a preset button (6) for two seconds. The preset number will appear on the LCD.

Recall a Station

Select a band (if needed). Press a preset button (6) to select the corresponding stored station.

Automatically Store / Preset Scan (A/PS)

Automatically Store

Select an AM or FM band. Press and hold the **A/PS** button (5) for more than 2 seconds to automatically select six strong stations and store them in the current band. The new stations replace any stations already stored in that band. This feature is most useful when traveling in a new area where you are not familiar with the local stations.

Preset Scan

Select a band. Press **A/PS** (5) to scan stations stored in the current band. The unit will pause for 5 seconds at each preset station. Press **A/PS** again to stop scanning when the desired station is reached.

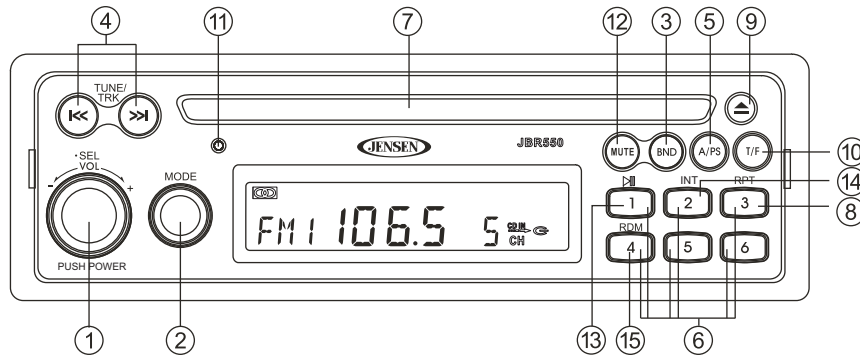

CD PLAYER OPERATION

Inserting and Ejecting a Disc

Insert a disc, label-side up, into the disc slot (7). The unit will automatically draw the disc in and play the first track on the disc, whether the power was turned on or not.

Press the eject  button (9) to stop disc play and eject the disc. The unit will revert to radio operation.

If an ejected disc is not removed within 10 seconds, it will automatically be reloaded to prevent damage to the CD (CD-IN icon appears on the display panel).

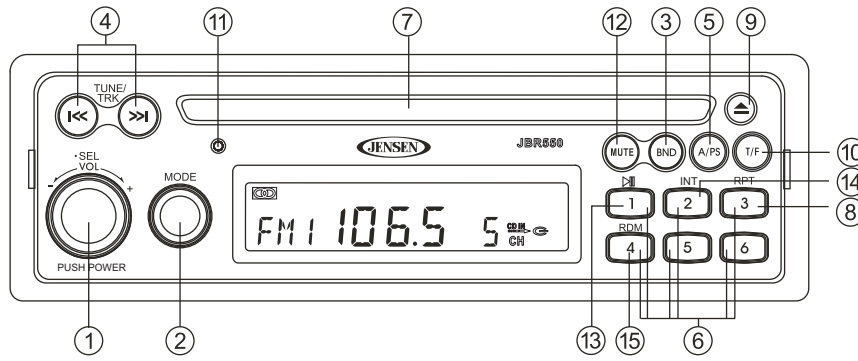

Controlling Disc Playback

Selecting Tracks

Press the **TUNE/TRK >>|** or **|<<** button (4) to advance to the next track on the disc. The selected track number will appear on the display.

Fast Forward/Fast Reverse

Press *and hold* the **TUNE/TRK >>|** or **|<<** button (4) to fast forward or fast reverse through the disc. Disc play starts when the button is released.

Play/Pause Disc Playback

Press the **1/>||** button (13) to pause disc play. The display will flash while paused. Press the **1/>||** button again to resume disc Play.

Previewing Tracks (Intro)

Press the **2/INT** button (14) to play the first 10 seconds of each track sequentially. Press **2/INT** again to stop Intro Scan and resume normal play at the current track.

Repeat Play

- Press the **3/RPT** button (8) during disc play to repeat play the current track.
- Press **3/RPT** again to stop repeat play.

Random Play

- Press the **4/RDM** button (15) during disc play to play all tracks in random, shuffled order.
- Press **4/RDM** again to stop random play.

CARE AND MAINTENANCE

- Keep the product dry. If it does get wet, wipe it dry immediately. Liquids might contain minerals that can corrode the electronic circuits.
- Keep the product away from dust and dirt, which can cause premature wear of parts.
- Handle the product gently and carefully. Dropping it can damage circuit boards and cases, and can cause the product to work improperly.
- Wipe the product with a dampened cloth occasionally to keep it looking new. Do not use harsh chemicals, cleaning solvents, or strong detergents to clean the product.
- Use and store the product only in normal temperature environments. High temperature can shorten the life of electronic devices, damage batteries, and distort or melt plastic parts.

Ignition

The most common source of noise in reception is the ignition system. This is a result of the radio being placed too close to the ignition system (engine). This type of noise can be easily detected because it will vary in intensity of pitch with the speed of the engine.

Usually, the ignition noise can be suppressed considerably by using a radio suppression type high voltage ignition wire and suppressor resistor in the ignition system. (Most vehicles employ this wire and resistor but it may be necessary to check them for correct operation.) Another method of suppression is the use of additional noise suppressors. These can be obtained from most professional mobile electronics retailers.

Interference

Radio reception in a moving environment is very different from reception in a stationary environment (home). It is very important to understand the difference.

AM reception will deteriorate when passing under a bridge or when passing under high voltage lines. Although AM is subject to environmental noise, it has the ability to be received at great distance. This is because broadcasting signals follow the curvature of the earth and are reflected back by the upper atmosphere.

TROUBLESHOOTING

Symptom	Cause	Solution
No power	The vehicle's accessory switch is not on	If the power supply is properly connected to the vehicle's accessory terminal, switch the ignition key to "ACC".
	The fuse is blown	Replace the fuse.
Disc cannot be loaded or ejected	Presence of CD disc inside the player	Remove the disc in the player and insert the new one.
	Inserting the disc in reverse direction	Insert the compact disc with the label facing upward.
	Compact disc is extremely dirty or disc is defective	Clean the disc or try to play a new one.
	Condensation	Leave the player off for an hour or so, then try again.
No sound	Volume is too low	Adjust volume to audible level.
	Wiring is not properly connected.	Check wiring connections.
The operation keys do not work	Control panel not properly installed	Reinstall control panel.
	The built-in microcomputer is not operating properly due to noise	Press the RESET button.
Sound skips	The installation angle is more than 30 degrees.	Adjust the installation angle to less than 30 degrees.
	The disc is dirty or defective.	Clean the disc and try to play again or use new disc.
Cannot tune to radio station, auto-seek does not work	The antenna cable is not connected.	Insert the antenna cable firmly.
	The signals are too weak.	Select a station manually.

SPECIFICATIONS

CD

Signal to Noise Ratio ≥ 55 dB
Channel Separation : More than 50 dB
Frequency Response : 20 Hz - 20 kHz

FM Radio

Frequency Coverage 87.5 to 107.9 MHz
Sensitivity (S/N=30dB) $4\mu\text{V}$
Image Rejection >45 dB
Stereo Separation >25 dB

AM/MW

Frequency Range 530-1710 kHz
Sensitivity (S/N=20dB) 36 dB

General

Operating Voltage DC 12 Volts
Grounding System Negative Ground
Speaker Impedance 4-8 ohms per channel

Tone Controls:

Bass (at 100 Hz) : ± 10 dB
Treble (at 10 kHz) : ± 10 dB

Power Output 40W x 4
Current Drain 10 Amp (max.)
Dimensions 183mm (W) x 158mm (D) x 58mm (H)



ASA Electronics Corporation

www.asaelectronics.com

© 2010 ASA Electronics Corporation

v.121709