

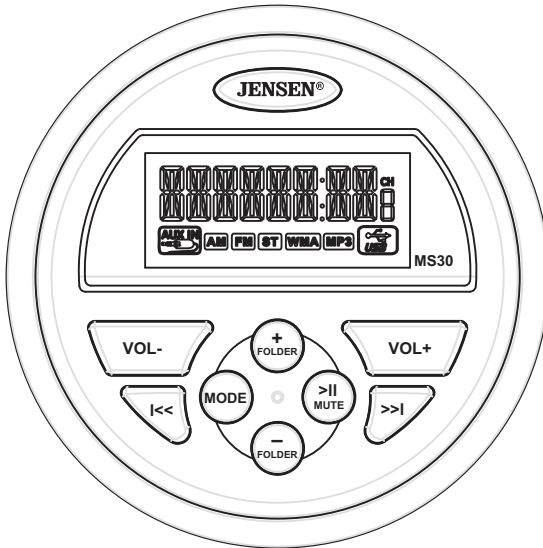

DESIGNED TO MOVE [YOU]

MS30

Owner's Manual



CONTENTS

Introduction	1
Features	1
Box Contents.....	1
Compliance	1
Safety Information	2
Installation	3
Mounting the Radio	3
Auxiliary Input.....	4
Line Output.....	4
Wiring Diagram	5
Operation	6
Basic Functions.....	6
Audio Menu	7
Radio Mode.....	7
USB Mode.....	8
Auxiliary Input Mode.....	8
Troubleshooting.....	9
Specifications.....	10

INTRODUCTION

Thank you for choosing a Jensen product. We hope you will find the instructions in this owner's manual clear and easy to follow. If you take a few minutes to look through it, you'll learn how to use all the features of your new Jensen receiver for maximum enjoyment.

Features

- Waterproof iPx6
- UV and Corrosion Resistant
- AM/FM Tuner
- 12 Programmable Presets (6 AM, 6 FM)
- USB MP3/WMA Player
- Rear Auxiliary Audio Input
- Rear Line Output
- 4-Channel Amplified Audio Output

Box Contents

- MS30 Radio
- Radio Mounting Bracket
- Screw Posts (x2)
- Locking Hex Nuts (x2)
- Washers (x2)

Compliance

Compliance with FCC Rules (U.S.A. Only)

This device complies with Part 15 of the FCC rules. Operation is subject to the following two conditions: (1) This device may not cause harmful interference, and (2) this device must accept any interference received, including interference that may cause undesired operation.

NOTICE

This equipment has been tested and found to comply with the limits for a Class B digital device, pursuant to Part 15 of the FCC rules. These limits are designed to provide reasonable protection against harmful interference in a residential application. This equipment generates, uses, and can radiate radio frequency energy and, if not used in accordance with the instructions, may cause harmful interference to radio communications.

FCC WARNING

- Changes or modifications not expressly approved by the party responsible for compliance could void the user's authority to operate this equipment.
- Proper connections must be used for connection to a host computer and/or peripherals in order to meet FCC emission limits.

Safety Information

- To ensure full satisfaction with the product, please read the entire instruction manual.
- Keep instructions for future reference.
- Follow all operation guidelines and adhere to all safety warnings and cautions to ensure safe use.
- Do not install near any heat sources such as radiators, heat registers, stoves, or other apparatus (including amplifiers) that produce heat.
- Only use attachments/accessories specified by the manufacturer.
- Never use harsh cleaning agents. Clean only with a dry cloth.

When Driving

Keep the volume level low enough to be aware of your surroundings.

Protect from Water

Do not submerge, as this can cause electrical shorts, fire or other damage.

Protect from High Temperatures

Exposure to direct sunlight for an extended period of time can produce very high temperatures inside your vehicle. Give the interior a chance to cool down before starting playback.

Do not mount the radio within close proximity of the engine compartment.

Use the Proper Power Supply

This product is designed to operate with a 12 volt DC negative ground battery system.

WARNING:

- DO NOT OPEN, DISASSEMBLE OR ALTER THE UNIT IN ANY WAY. Doing so may result in fire, electric shock or product damage.
- USE THE CORRECT AMPERE RATING WHEN REPLACING FUSE. Failure to do so may result in fire, electric shock or product damage.
- DO NOT INSTALL IN LOCATIONS THAT MIGHT HINDER VEHICLE OPERATION. Doing so may obstruct vision or hamper movement which can result in a serious accident.
- INSTALL THE WIRING SO THAT IT IS NOT CRIMPED OR PINCHED BY SCREWS OR SHARP METAL EDGES. Route the cables away from moving parts or sharp pointed edges. This will prevent crimping and damage to the wiring. If the wiring must pass through a metal hole, be sure to use a rubber grommet to prevent the wire's insulation from being cut by the metal edge of the hole. It is also recommended to apply sealing caulk to any opening that may potentially allow water to enter.
- Be sure to choose a location that is flat and has clearance above the unit to prevent any damage, as well as allow for ventilation.
- Before drilling any holes, carefully inspect the area underneath and behind the mounting surface where the device will be mounted to make sure it will not interfere with existing wires, fuel lines, the fuel tank or any other objects that could be damaged.
- Always disconnect the vehicle negative battery terminal during installation to prevent accidental shorting.

INSTALLATION

Mounting the Radio

1. Choose a mounting location on the dash board or instrument panel that will allow room behind to run radio cables to the power source. Consider how you will use the AUX IN, LINE OUT and USB connectors and route the appropriate extension cables to an accessible area.
2. Cut a hole in the dash board using the template provided in the back of this manual. At least 3 3/4" depth is needed to mount the radio.

IMPORTANT! Do not mount this unit where it can be submerged in water.

3. Slide the included spring washers (B) over the screw posts (A) and attach the screw posts to the back of the radio.
4. Place the radio in front of the dashboard opening so the wiring can be brought through the opening.
5. After completing the wiring connections, turn the radio on to confirm operation (vehicle accessory switch must be on). If the radio does not operate, recheck all wiring until the problem is corrected. Once proper operation is achieved, turn the accessory switch off and proceed with final mounting of the radio. Refer to the "Wiring Diagram" on page 5.

NOTE: Before final installation, test the wiring connections to make sure the unit is connected properly and the system works.

6. Insert the radio into the mounting hole.
7. Place the "U" bracket (C) over the screw posts and secure the radio to the dash using the included hex nuts (D). If necessary, cut the score marks (E) on either side of the mounting bracket to custom fit the bracket length for your application. See Figure A.

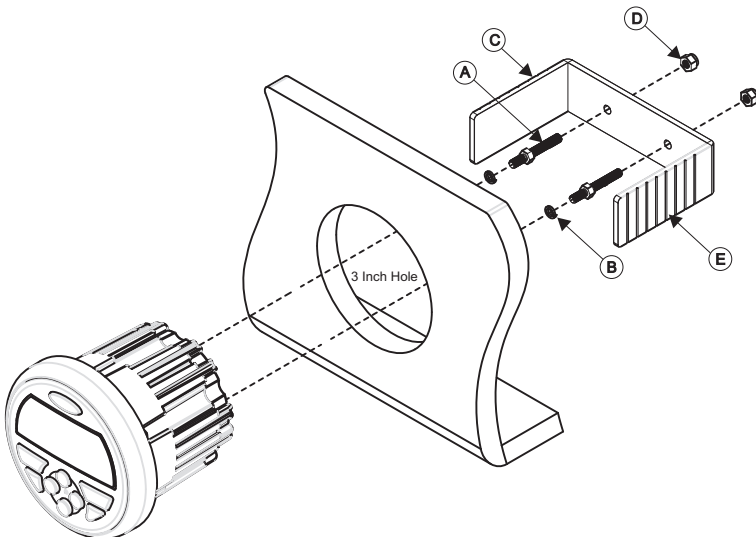

Figure A - Installation

Auxiliary Input

Connect a portable audio device to the Audio Input (AUX IN RIGHT/LEFT) on the back of the unit using RCA cables.

Line Output

The Line Out connectors (LINE OUT RIGHT/LEFT) on the back of the unit output a line-level analog signal. Use this output to connect to an external amplifier.

Wiring Diagram

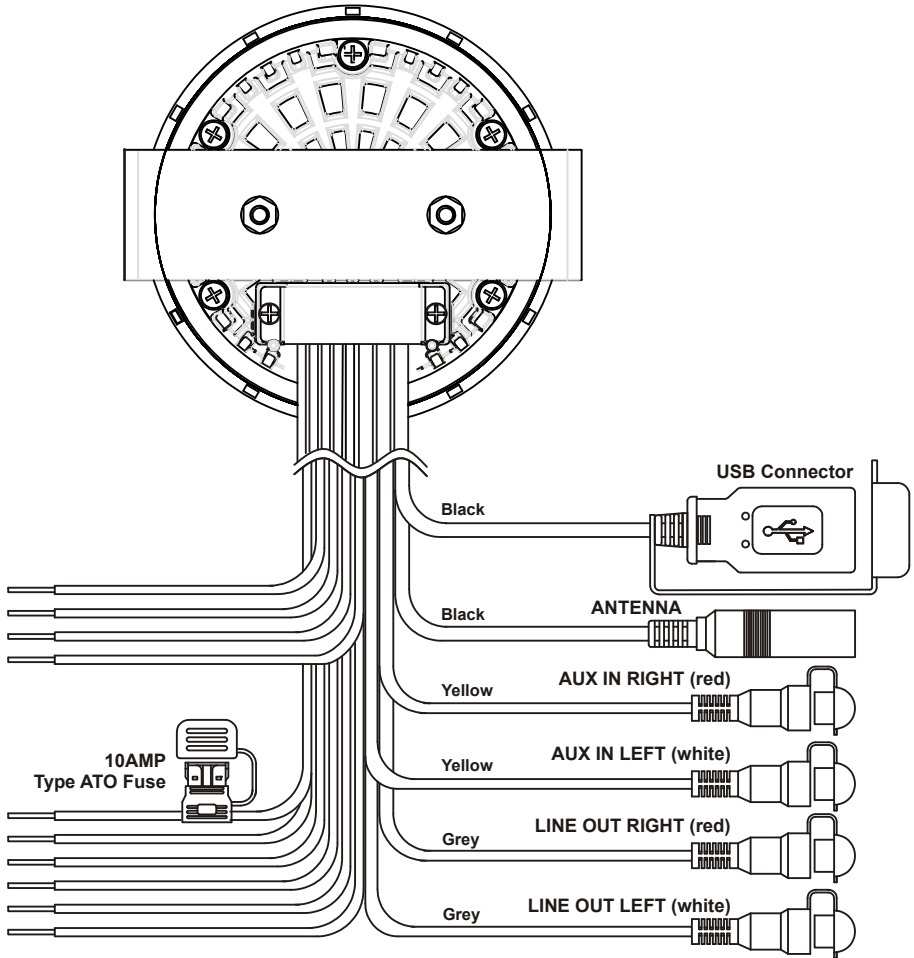

WIRE COLOR	DESCRIPTION
PURPLE	REAR RIGHT SPEAKER (+)
PURPLE/BLACK	REAR RIGHT SPEAKER (-)
GRAY	FRONT RIGHT SPEAKER (+)
GRAY/BLACK	FRONT RIGHT SPEAKER (-)
WHITE	FRONT LEFT SPEAKER (+)
WHITE/BLACK	FRONT LEFT SPEAKER (-)
GREEN	REAR LEFT SPEAKER (+)
GREEN/BLACK	REAR LEFT SPEAKER (-)
RED	+12 VDC SWITCHED
BLACK	GROUND

NOTE: Do not connect the red wire to a constant power connection. The red wire should be connected to a vehicle connection with switched power, such as IGN or ACC.

OPERATION

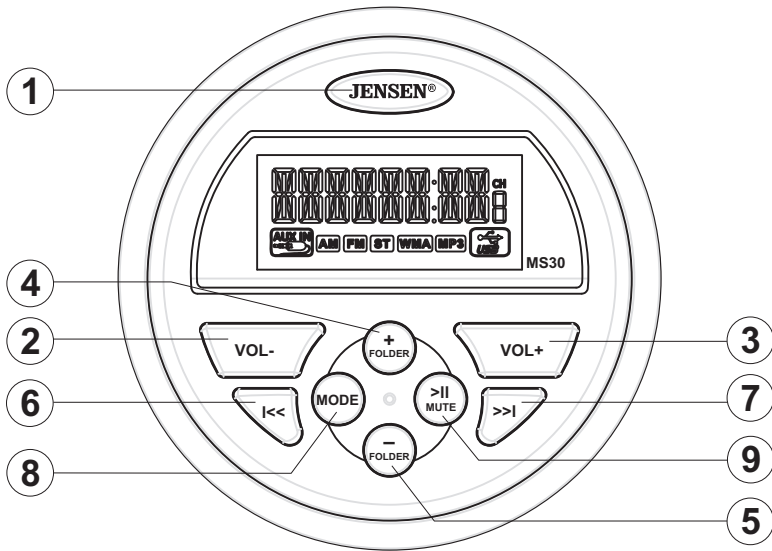

Basic Functions

Power

Press the **JENSEN** power button (1) to turn the unit on/off.

Restore Factory Settings

Perform the following steps to reset the radio to factory default settings:

1. Press and hold the power button (1) to display the software version.
2. Press the **VOL +** button (3) to display "RESET".
3. Press the power button to confirm factory default restore. After reset, the unit will default to FM mode.

Volume

Press the **VOL +** button (3) to increase the volume.

Press the **VOL -** button (2) to decrease the volume.

Press and hold either button to change the volume level quickly.

Mute

Press the **MUTE** button (9) to silence the audio output in tuner, AUX or USB mode. Press again to restore the previous volume level.

Mode

Press the **MODE** button (8) to select a mode of operation: FM, AM, AUX or USB.

Audio Menu

Press and hold the **MODE** button (8) to access the audio menu. Press the **MODE** button repeatedly to adjust the following settings: BASS, TREBLE, BALANCE, FADER, AS and PS. Use the **VOL +/-** buttons (3, 2) to choose a value for each setting. See "Radio Mode" for instructions regarding the Auto Store (AS) and Preset Scan (PS) features.

Radio Mode

USA/Europe (EURO) Tuning Mode Selection

To change from USA to European tuning mode, perform the following steps:

1. Press and hold the **MODE** button (8) for 2 seconds to access the system menu.
2. Press the **MODE** button repeatedly to move through the menu options (BASS > TREBLE > BALANCE > FADER > AS/PS > USA/EURO). The unit will display USA (if set to USA frequency tuning mode) or EURO (if set to European frequency mode).
3. With the display showing the current tuning mode, press the **VOL -** or **VOL+** button (2, 3) to change between USA/EURO.
4. Press the **JENSEN** power button (1) to confirm your selection.

Frequency Tuning

Press the **I<<** or **>>I** button (6, 7) to fine tune the radio frequency.

Channel Seek

Press and hold the **I<<** or **>>I** button to seek strong radio frequencies.

Preset Channel Store

To manually store a favorite channel to one of the six preset channels, perform the following steps:

1. Press the **I<<** or **>>I** button (6, 7) to tune to the radio frequency you want to store.
2. Press and hold the **FOLDER +** or **-** button (4, 5) to access the preset channel list.
3. Press the **I<<** or **>>I** button to select the desired preset channel number (1-6).
4. Wait three seconds and the unit will save the station to the chosen preset channel and display "SAVED" on the screen.

Auto Store

Press and hold the **MODE** button (8) to access the audio menu. Press the **MODE** button repeatedly until "AS" appears on the display. Press the **>>I** button to begin the Auto Store function and store the strongest stations to the preset tuning channels. The unit will automatically perform a Preset Scan once the Auto Store is complete.

Preset Scan

Press and hold the **MODE** button to access the audio menu. Press the **MODE** button repeatedly until "PS" appears on the display. Press the **>>I** button to begin the Preset Scan function and listen to a preview of each stored station.

Preset Channel select

Press the **FOLDER +/-** buttons (4, 5) to select available preset channels.

USB Mode

Insert/Remove USB Device

You can connect a USB device directly to the USB interface at the rear of the radio for playback of compatible files. Playback begins automatically.

Press the **MODE** button (8) to switch to USB mode from another source.

Play/Pause (USB)

During USB playback, press the **MUTE** button (9) to play or pause the selected track.

Next/Previous File

Press the **I<<** or **>>I** button (6, 7) to select the previous or next track.

Folder Navigation

Press the **FOLDER +/-** buttons (4, 5) to select the next/previous folder. Playback will begin with the first song file in the selected folder.

Fast Forward/Fast Reverse

Press and hold the **I<<** or **>>I** button to fast forward or fast reverse.

Auxiliary Input Mode

Press the **MODE** button (8) to directly access auxiliary input mode (AUX IN) from any other mode when a portable audio device is connected to the unit.

TROUBLESHOOTING

Table 1: Troubleshooting

Problem	Solution
No Power	If the power supply is connected to the vehicle accessory circuits but the engine is not on, switch the ignition key to "ACC"
	Fuse may be blown. Replace with 10 AMP ATO fuse.
No AM/FM Reception	Antenna cable not connected; insert antenna cable firmly.
No Sound	Check volume level; increase volume if necessary.
	Check power; make sure device is on.
	Check device; press the play/pause button to ensure unit is not in Pause mode.



SPECIFICATIONS

General

Power Supply Requirements DC 12 Volts, Negative Ground
 Operating Voltage 10-16VDC
 Unit Dimensions 3.0" Diagonal, 3.3" Deep
 Mounting Dimensions 3.0" Diagonal, 4" Deep
 Weight 1 lb.

FM Tuner

Tuning Range 87.5-107.9FM
 Sensitivity <4uV
 Stereo Separation @ 1 kHz. >25dB

AM Tuner

Tuning Range 530-1710
 Sensitivity <63uV

Amplifier

Max Output Power. 160 Watts Total (40 Watts, 4 Channel)
 Output Impedance. Compatible with 4-8 Ohm Speakers, 4 Ohm Load Minimum

Specifications subject to change without notice.



ASA Electronics Corporation

www.asaelectronics.com

www.jensenheavyduty.com

www.jensenmarinedirect.com/

©2017 ASA Electronics Corporation

v. 120517